



Project:

Item Number:

Quantity:

SU412X SINGLE FLAVOR, PRESSURIZED SHAKE FREEZER WITH REFRIGERATED CABINET



DESCRIPTION

Single flavor, pressurized shake freezer with refrigerated cabinet provides greater reliability and quieter operation with Stoelting's high-efficiency evaporator and Scroll Compressor. Proprietary auger design gently folds mix and prevents product breakdown. Refrigerated mix storage cabinet has a slide-out mix shelf and a non-contact mix-pump system. Built for consistent control of all mixes.

ITEMS

- SU412X-302I** Air-cooled, single-phase, front mount spinner

ACCESSORIES & OPTIONS

- Front Door Mounted Spinner (S Prefix)** Dispensing and mixing product is accomplished with a single front-mounted handle for fastest speed of service.

FEATURES

- NSF approved food-grade plastic blades provide quiet operation and superior durability.
- Adjustable speed on the mixer.
- Simplified design for quick assembly after cleaning.
- Clear door displays circulating product for merchandising appeal.
- Highly efficient auger design gently folds the entire contents of the freezing cylinder, delivering a thick, smooth, and creamy product.
- Pump approved for clean-in-place, reducing cleaning time and labor requirements.
- Mix containers in the refrigerated storage cabinet safely hold up to 8 gallons of mix, providing enough product during peak times and reducing the frequent refills.
- Tamper-proof controls for self-serve applications.
- Reliable and quiet with the combination of Stoelting's evaporator system and the Scroll™ compressor.
- Mix pumps inject the exact amount of air into your mix, maintaining overrun to ensure maximum profitability.

 Every machine includes Stoelting's White Glove Service. One call does it all – customer service, technical service, parts or warranty information, installation, startup, sales, on-site service dispatch and much more. Available 24 hours a day, seven days a week year-round.

Continuous research leads to ongoing product improvements; therefore, these specifications are subject to change without notice and should not be used as installation specifications.

Approvals	Date

SU412X SINGLE FLAVOR, PRESSURIZED SHAKE FREEZER WITH REFRIGERATED CABINET

DIMENSIONS

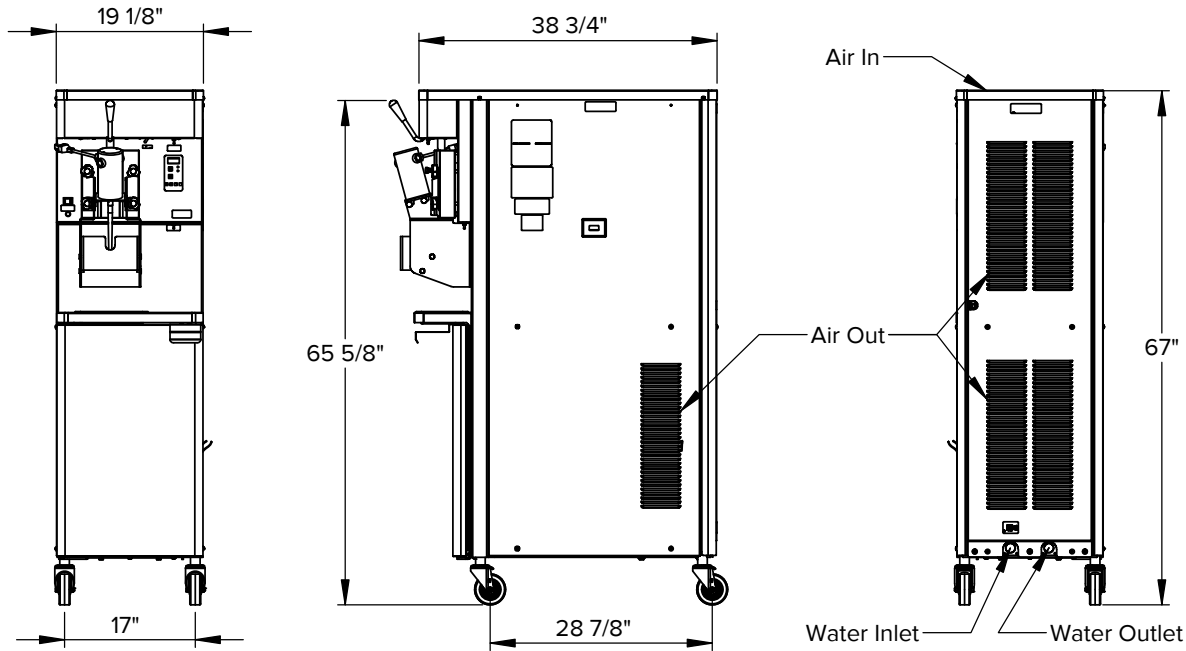

Height dimensions may vary ±1" due to casters

GENERAL SPECIFICATIONS

Freezing Cylinder				Cabinet Capacity gallon (L)	Drive Motor (hp)	Weight lb (kg)	Crated Weight lb (kg)
Capacity gallon (L)	Compressor						
	Btu/hr	Refrigerant	Charge (oz)				
2.1 (7.95)	11,000	R-448A	34 oz	8 (30.3)	3/4	450 (204.1)	550 (249.5)

- Indoor use only.
- Maximum ambient temperature: 100°F (37.8°C).
- Requires a dedicated electrical circuit.
- Electrical plug not included. Hardwired connection required.
- Air cooled units require: 3" (7.6 cm) air space on both sides and 6" at the back.
- Water cooled units require: 1/2" N.P.T. water and drain fittings. Maximum water pressure of 130 psi. Minimum water flow rate of 3 GPM. Ideal EWT of 50°-70°F.
- Details on CAD Revit Symbols Libraries are available on www.stoelting.kclcad.com.

ITEM NUMBER SPECIFICATIONS

Model Number	Cooling	Phase	Volts	Hz	Maximum Overcurrent Protection Device (Amps)	Minimum Circuit Ampacity (Amps)	Front Door Mounted Spinner
SU412X-302I	Air	1	220-240	50	30	19	✓



Service Information
 800-319-9549 (U.S. Toll Free)
 920-894-2293 (Outside the U.S.)
www.stoeltingfoodservice.com
www.vollrath.com